



Base Models: F330, F33

36" Wide Ranges



F33



-24



-2RB



LOG4
(lift off griddle)



F330

Standard Features & Benefits

OVEN: 31.5" w x 22" d x 14" h for superior baking characteristics and results. Heavy insulation for fuel efficiency. Easy cleaning porcelain and aluminized linings with one nickel plated rack. 3 rack positions with 2.5" between rack positions. Long life, 30,000 BTU cast iron "H" pattern oven burner combined with special "V" shaped baffle directs heat for excellent air circulation.

COOK TOPS: 24,000 BTU "star" pattern top burners offer a more efficient burn pattern for small to large pots. Full width crumb trays catch all spillage. Top grates are 12" x 12" cast iron with spillover bowl that also reflects heat for added efficiency. Designed for easy movement of pots across top sections. Wide, stainless steel bull nose landing across the front is a functional work area for service plates and work utensils and also serves as control protection.

CONSTRUCTION: Easy cleaning, corrosion resistant stainless steel finish, welded with angle iron and aluminized inner framing. Sturdy 6" heavy duty stainless pipe legs with adjustable feet. Double wall construction with heavy insulation for cooler operation. Installation clearances for non-combustible surfaces are 0" on sides and 0" in the rear, combustible surface clearances are 2" and 2".

CONTROLS: Includes 500° thermostat, 100% safety shut off, automatic standing pilot and brass top burner valves. Orifices and pressure regulators are set at the factory for the gas specified. Optimal pressures are 4" WC for natural gas and 10" WC for propane. Manifold size is 3/4" NPT. All controls are tested and confirmed in good working order. Calibration and adjustments are the responsibility of the installer.

Optional Features

GRIDDLE PLATES: Available in 12" width increments. 3/4" thick to hold heat from long life, 20,000 BTU cast iron "H" pattern burners. Plates also feature a front "cold zone" grease trough and large capacity grease catch. Thermostats, safety pilots, chrome and thicker plates are also available.

RADIANT CHAR-BROILERS: 25,000 BTU cast iron "H" pattern burners. Cast iron top grate sections fit into 12" width increments. A cast-in trough on each blade channels grease into the front cold zone grease trough reducing flare up. Each section is reversible for sloped or level cooking. Stainless steel splash guards on 3 sides graduating up to 4" high. Grease slot is 3.5" x 1" and feeds into a large, removable grease drawer. Char-broilers are approved for use in non-combustible locations only.

HOT TOPS: Available in 12" width increments in lieu of open top burners. 3/4" thick to hold heat from long life, even heating 20,000 BTU cast iron "H" pattern burners.

ACCESSORIES & OPTIONS: Casters, extra racks, pizza decks, FD oven thermostats, oven spark pilots, chrome griddle plates, 1" thick griddle plates, griddle thermostats, safety pilot griddles, lift off griddles, grill scrapers, cleaning supplies, hose and quick disconnects, control protection bars, storage base in lieu of oven and low backs are some of the standard options and accessories available.



Comstock-Castle Stove Co. • 119 W. Washington • Quincy, IL 62301 USA
Tel.: 217-223-5070 • Telefax: 217-223-0007 • www.castlestove.com



36" WIDE SERIES MEASUREMENTS

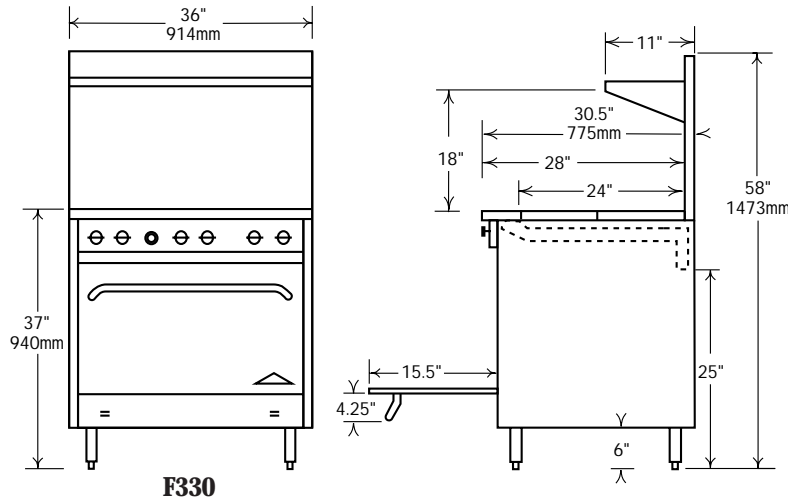

F330

36" Restaurant Range Series

Top Configuration	Model #	Description		Total B.T.U.	Approx. Ship Weight	
		Top	Base		(Kg)	(Lbs.)
	F330	(6) Open Burners	- w/ (1) 31.5" Oven	174,000	205	450
	F33	(6) Open Burners	- w/ (1) cabinet base	144,000	155	340
	F330-12	(4) Open Burners & (1) 12" Griddle	- w/ (1) 31.5" Oven	146,000	211	465
	F33-12	(4) Open Burners & (1) 12" Griddle	- w/ (1) cabinet base	116,000	167	365
	F330-1RB	(4) Open Burners & (1) 12" Radiant Broiler	- w/ (1) 31.5" Oven	151,000	209	460
	F33-1RB	(4) Open Burners & (1) 12" Radiant Broiler	- w/ (1) cabinet base	121,000	166	365
	F330-24	(2) Open Burners & (1) 24" Griddle	- w/ (1) 31.5" Oven	118,000	243	535
	F33-24	(2) Open Burners & (1) 24" Griddle	- w/ (1) cabinet base	88,000	193	425
	F330-2RB	(2) Open Burners & (1) 24" Radiant Broiler	- w/ (1) 31.5" Oven	128,000	209	460
	F33-2RB	(2) Open Burners & (1) 24" Radiant Broiler	- w/ (1) cabinet base	98,000	161	355
	F330-12-1RB	(2) Open Burners & (1) 12" Griddle & (1) 12" Radiant Broiler	- w/ (1) 31.5" Oven	123,000	211	465
	F33-12-1RB	(2) Open Burners & (1) 12" Griddle & (1) 12" Radiant Broiler	- w/ (1) cabinet base	93,000	170	375
	F330-36	(0) Open Burners & (1) 36" Griddle	- w/ (1) 31.5" Oven	90,000	245	540
	F33-36	(0) Open Burners & (1) 36" Griddle	- w/ (1) cabinet base	60,000	195	430
	F330-3RB	(0) Open Burners & (1) Radiant Broiler	- w/ (1) 31.5" Oven	105,000	209	460
	F33-3RB	(0) Open Burners & (1) Radiant Broiler	- w/ (1) cabinet base	75,000	168	370
	F330-12-2RB	(0) Open Burners & (1) 12" Griddle & (1) 24" Radiant Broiler	- w/ (1) 31.5" Oven	100,000	218	480
	F33-12-2RB	(0) Open Burners & (1) 12" Griddle & (1) 24" Radiant Broiler	- w/ (1) cabinet base	70,000	177	390
	F330-24-1RB	(0) Open Burners & (1) 24" Griddle & (1) 12" Radiant Broiler	- w/ (1) 31.5" Oven	95,000	209	460
	F33-24-1RB	(0) Open Burners & (1) 24" Griddle & (1) 12" Radiant Broiler	- w/ (1) cabinet base	65,000	168	370

Note: Radiant char-broiler sections and hot top available, add suffix -1RB, -2RB or -1HT, -2HT, etc. per section.

Top sections in lieu of open top burners are located on the right when viewing from the front. Special locations may require custom work and pricing, please call the factory for details.

Crated Dimensions: 39" (991mm) Wide x 37" (940mm) Deep x 37" (940mm) High.

Product improvement is a Comstock-Castle policy and may result in design and specification change without notice.